

# Ball Valve

## Design Feature:

- 3 Pc Design Construction
- Full Port
- Blow Out Proof Stem
- Flanged Ends

## Conformity to Standards & Codes :

Design & Face to Face Dimensions :  
BS 5351 / ISO 17292 / ASME B 16.10

Valve Testing : API 598

Flange Standard Conformity :  
ASME B 16.5 CL150,  
DIN PN 10 & 16

Size Range :  
15mm (1/2") to 150mm (6")

## Applications:

- Oil Refineries
- Compressed Air / Gas Installations
- Chemical & Solvent Industries
- Petrochemical Industries
- Process Industries

# VA-12

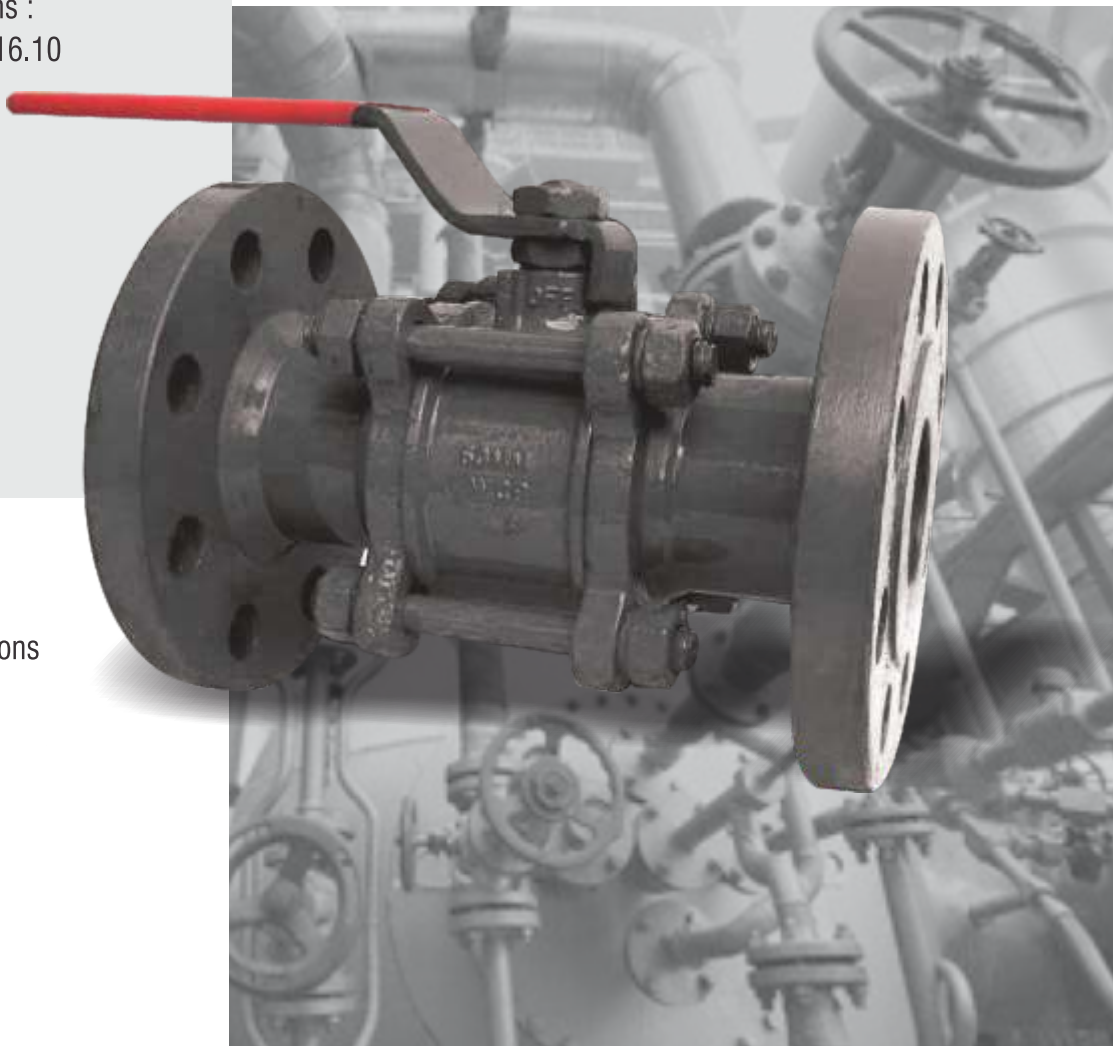

DOC. NO. : VAV-C-1005;REV.01;REV. DATE: 12-11-2014



## PART LIST

S. NO.	PART NAME	MATERIAL	SPECIFICATIONS	QTY
1.	BODY	CARBON STEEL/ STAINLESS STEEL	ASTM A216 GR. WCB/ASTM A351 GR. CF8/CF8M	1
2.	FLANGE	CARBON STEEL/ STAINLESS STEEL	ASTM A216 GR. WCB/ASTM A351 GR. CF8/CF8M	2
3.	BALL	STAINLESS STEEL	ASTM A351 GR. CF8/ CF8M / ASTM A276 GR. 304/316	1
4.	SPINDLE	STAINLESS STEEL	A276 GR. 304/316	1
5.	GLAND NUT	CARBON STEEL/ STAINLESS STEEL	ASTM A307 GR. B/AISI 304/316	1
6.	HAND LEVER	CARBON STEEL/ STAINLESS STEEL	ASTM A307 GR. B/AISI 304/316	1
7.	LOCK NUT	CARBON STEEL/ STAINLESS STEEL	ASTM A307 GR. B/AISI 304/316	1
8.	GLAND PACKING	PTFE	BS 6564	4
9.	SEAT RING	PTFE	BS 6564	2
10.	BODY SEAL	PTFE	BS 6564	2
11.	STUD	CARBON STEEL/ STAINLESS STEEL	ASTM A307 GR. B/AISI 304/316	4
12.	WASHER	CARBON STEEL/ STAINLESS STEEL	ASTM A307 GR. B/AISI 304/316	8
13.	NUT	CARBON STEEL/ STAINLESS STEEL	ASTM A307 GR. B/AISI 304/316	8
14.	HANDLE SLEEVE	PVC	BS 6076	1

\*Gland packing, body seal and seat ring, other than PTFE are available on request.

## DIMENSIONS

SIZE	A	B	C	D	E	F	G	H	I	J	K
15MM	108	14	35	90	53	138	10	2	60.3	16	4
20MM	117	19	43	100	55	155	10.9	2	69.9	16	4
25MM	127	24	51	110	59	155	11.6	2	79.4	16	4
32MM	140	31	63.5	115	76	174	13.2	2	88.9	16	4
40MM	165	38	73	125	81	200	14.7	2	98.4	16	4
50MM	178	50	92	150	90	200	16.3	2	120.7	19	4
65MM	190	63	105	180	128	296	17.9	2	139.7	19	4
80MM	203	76	127	190	138	296	19.5	2	152.4	19	4
100MM	229	100	157	230	172	390	24.3	2	190.5	19	8

\*All dimensions are in mm unless and otherwise specified.

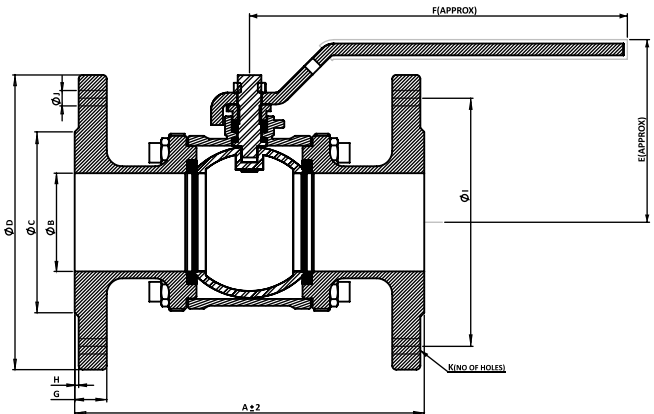
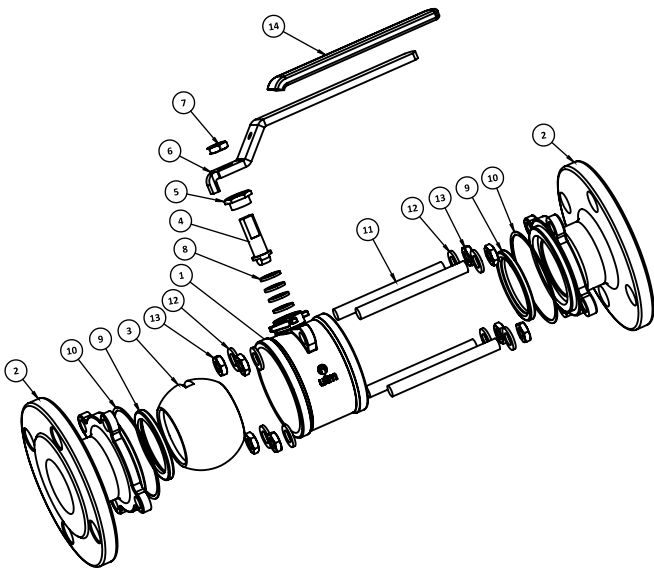

## TEST PRESSURE:

Type of Test	Pressure
Hydraulic Body Test	30 Kg/Cm <sup>2</sup>
Hydraulic Body Test	22 Kg/Cm <sup>2</sup>
Pneumatic Seat Test (Optional)	4-7 Kg/Cm <sup>2</sup>

## GUARANTEE

All valves are guaranteed against any manufacturing defects for a period of 12 months from date of supply, provided the valves have not been misused, damaged or installed for services they are not recommended. The company shall be liable to furnish part/ parts thereof or full valve as the company may deem fit

# V.A. VALVES

Regd. Office & Works: Udyog Nagar, Gadaipur, Jalandhar City -144 004  
Phone: +91-181-2601540, 2601541 Fax: +91-181-2601741  
E-mail : marketing@vk-utam.com, info@vtm-valves.com

Website : [www.vk-utam.com](http://www.vk-utam.com), [www.vtm-valves.com](http://www.vtm-valves.com)

Due to continuous development program, design and data in this leaflet are subject to change without prior notice.

Authorized Stockist

Our associates:



PIONEERING FLUID CONTROLS