

Sluice Valve

VA-15

Design Features:

- Press Fitted/Threaded Seat Rings
- Bubble Tight Sealing
- Long Wear Travel of Seat Rings for Longer Service Life
- Non-Rising Stem
- Perfect interchangeability & renewability of components.
- Bypass Arrangement Available on request

Conformity to Standard & Codes:

Design Standard: IS:14846

Face to Face Dimension:

IS:14846-Preferred Dimensions

End Detail: Flanged conforms to

- IS:1538
- BS:4504 PN10/16
- BS:10 Table D/E
- ASME B16.5 #150

Valve Testing: IS:14846

Applications:

- Water Distribution Network
- Waste Management System
- Irrigation System.
- Pulp & Paper Industry
- Fire Hydrant System



QUALITY INDUSTRIAL VALVES

DOC. NO. : VAV-C-1006; REV. : 02; REV. DATE : 04-06-2019



CM/L NO.: 9630179

PART LIST

S.NO.	PART NAME	MATERIAL	SPECIFICATIONS	QTY.
1.	BODY	GREY CAST IRON	IS 210 GR. FG 200	1
2.	BONNET	GREY CAST IRON	IS 210 GR. FG 200	1
3.	WEDGE	GREY CAST IRON	IS 210 GR. FG 200	1
4.	SPINDLE	STAINLESS STEEL	IS 6603	1
5.	BODY SEAT RING	BRONZE	IS 318 GR. LTB 2	2
6.	WEDGE SEAT RING	BRONZE	IS 318 GR. LTB 2	2
7.	WEDGE NUT	DUCTILE IRON/BRASS	IS 1865 GR. 500/7 / IS 320 GR. HT 2	1
8.	STUFFING BOX	GREY CAST IRON	IS 210 GR. FG 200	1
9.	GLAND FLANGE	GREY CAST IRON	IS 210 GR. FG 200	1
10.	BONNET/STUFFING BOX GASKET	RUBBER	NBR/EPDM	1
11.	GLAND PACKING	RUBBER	NBR/EPDM	4
12.	BODY/BONNET GASKET	RUBBER	NBR/EPDM	1
13.	HAND WHEEL	GREY CAST IRON/DUCTILE IRON	IS 210 GR. FG 200/ IS 1865 GR. 500/7	1
14.	WASHER	CARBON STEEL	IS 1363/ASTM A307 GR. B	---
15.	FASTENERS	CARBON STEEL	IS 1363/ASTM A307 GR. B	---

TEST PRESSURE

SIZE	SHELL	SEAT
PN 10	15.0 kg/cm ²	11.0 kg/cm ²
PN 16	24.0 kg/cm ²	17.6 kg/cm ²

DIMENSIONS

SIZE (mm)	A	B	C	D	E	F	G	H	I
50	178	50	165	125	16.0	19	4	365	225
65	190	65	185	145	16.0	19	4	380	225
80	203	80	200	160	21.0	19	4	425	225
100	229	100	220	180	22.0	19	8	470	320
125	254	125	250	210	22.5	19	8	485	320
150	267	150	285	240	23.0	23	8	595	320
200	292	200	340	295	24.5	23	8	725	360
250	330	250	395	350	26.0	23	12	835	400
300	356	300	445	400	27.5	23	12	910	400
350	381	350	505	460	29.0	23	16	1030	500
400	406	400	565	513	30.0	28	16	1110	640
450	432	450	615	565	31.5	28	20	1210	720
500	457	500	670	620	33.0	28	20	1340	720
600	508	600	780	725	36.0	31	20	1500	720

*Note: Flange dimensions are as per IS 1538 in table. Same are available in other standard on request.

GUARANTEE

All valves are guaranteed against any manufacturing defects for a period of 12 months from date of supply, provided the valves have not been misused, damaged or installed for services they are not recommended. The company shall be liable to furnish part/ parts thereof or full valve as the company may deem fit.

V.A. VALVES

ISO 9001-2008 Certified

Regd. Office & Works: Udyog Nagar, Gadaipur, Jalandhar City -144 004

Phone: +91-181-2601540, 2601541 Fax: +91-181-2601741

E-mail : marketing@vk-utam.com, info@vtm-valves.com

Website : www.vtm-utam.com

Due to continuous development program, design and data in this leaflet are subject to change without prior notice.

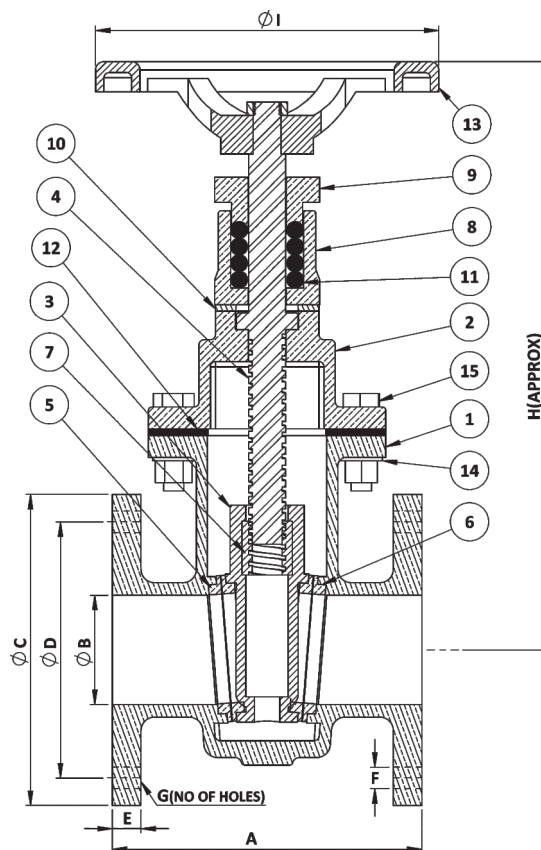

Authorized Stockist

Our associates:



PIONEERING FLUID CONTROLS