

Cast Steel Swing Check Valve

150# / 300#

VA-130
VA-131

Designs Features:

- Robust one piece construction to withstand the severe shock of check valve service.
- Short Distance of travel, combined balanced disc allows rapid closure while minimizing slamming.
- Tilting & free to rotate Disc Design to avoid localized wear.
- Flat Seat Design at angle for Longer Life.
- Can be installed Horizontally, Vertically and Inclined.
- Ground & lapped seating surface.
- Perfect interchangeability of compc.
- Easy to Maintain, Long Life and Trouble Free Operation.

Conformity to Standards and Codes:

Design: API 6D/BS1868

Face to Face: API 6D/ASME B16.10

End Connection: Flanged Ends to Suit ASME B16.5 #150/#300

Butt-Weld Ends to Suit ASME B16.25

Range: 40mm (1.1/2") to 300mm (12")

Valve Testing: API 6D/ISO 5208

Applications:

- **Energy-** Power Generation, Oil and Gas, Refining etc
- **Processing-** Chemical Processing, Pulp and Water, Food and Beverages, Petro Chemicals etc
- **Other Industries-** Marine,

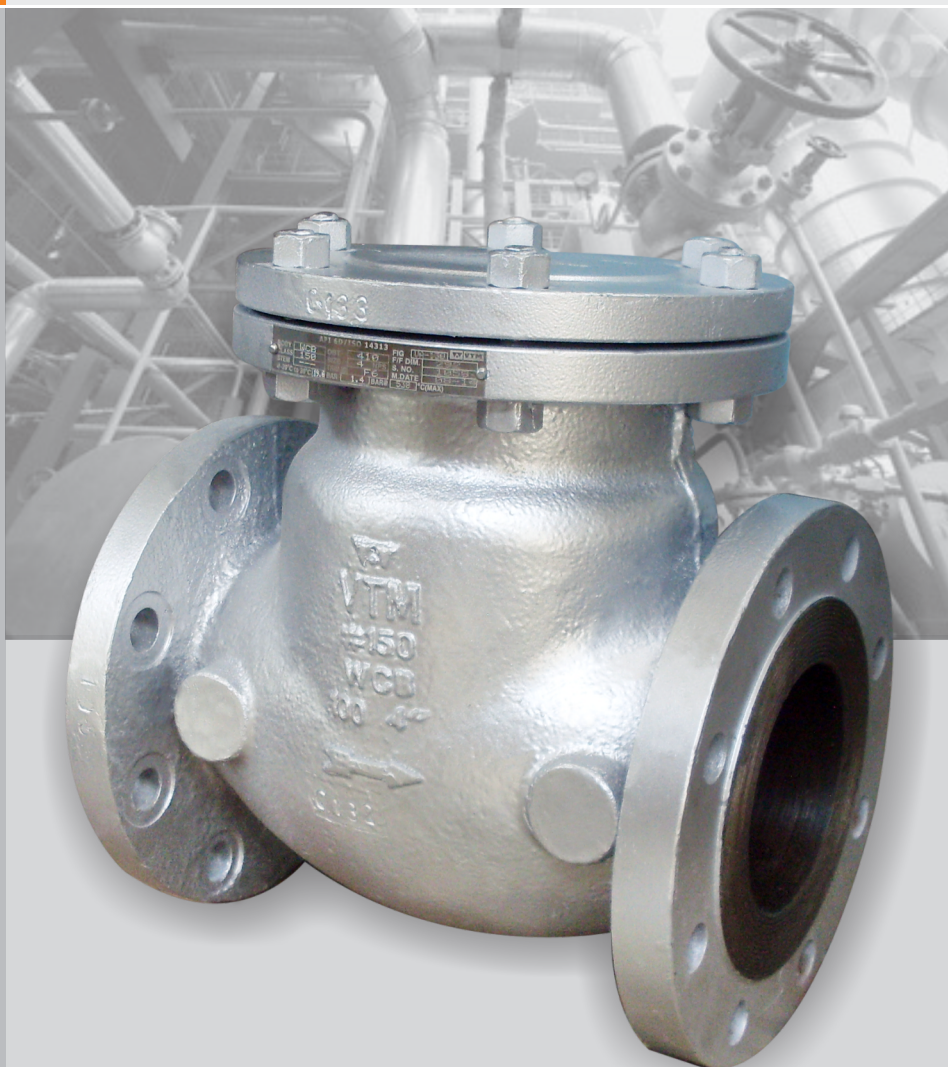

DOC. NO. : VAV-C-1026; REV. NO. : 02; REV. DATE : 15-05-2019



www.vtm-valves.com

PART LIST

S.NO.	PART NAME	MATERIAL	SPECIFICATION	QTY.
1.	BODY	CAST CARBON STEEL	ASTM A216 GR.WCB	1
2.	COVER	CAST CARBON STEEL	ASTM A216 GR.WCB	1
3.	DISC	CARBON/STAINLESS STEEL	ASTM A217 GR.CA15/ ASTM A276 GR. 410	1
4.	SEAT RING	STAINLESS STEEL	ASTM A217 GR.CA15	1
5.	HINGE	CAST CARBON STEEL	ASTM A216 GR.WCB	1
6.	GASKET	STAINLESS STEEL	ASTM B16.20 SPIRAL WOUNDED(SS304/316)	1
7.	WASHER	CARBON STEEL	EN 8	1
8.	BODY/COVER STUDS	CARBON STEEL	ASTM A193 GR.B7	-
9.	BODY/COVER NUT	CARBON STEEL	ASTM A194 GR.2H	-
10.	HINGE PIN	STAINLESS STEEL	ASTM A276 GR. 410	1
11.	EYE BOLT	STAINLESS STEEL	ANSI/ASME B18.15, C-1030	1
12.	HINGE BOLT	CARBON STEEL	ASTM A193 GR.B7	1
13.	HANGER NUT	CARBON STEEL	ASTM A194 GR.2H	2

Note : Contact Factory for other Technical Details / Material in Special Grades

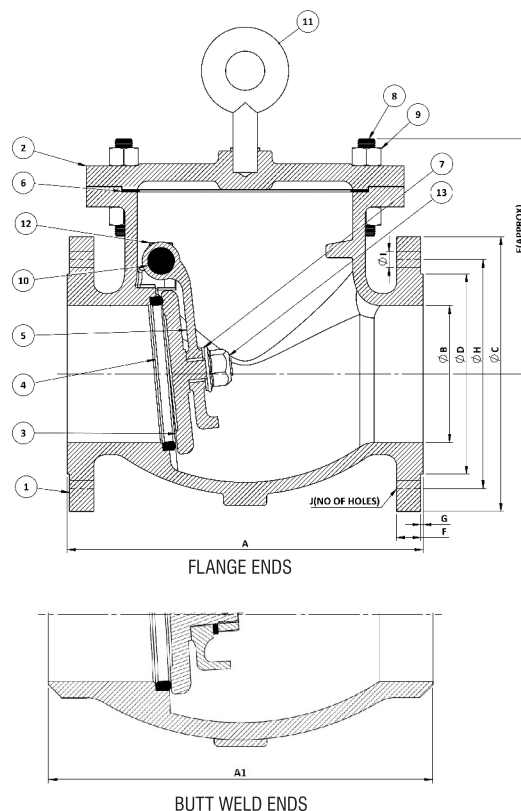

DIMENSIONS #150

SIZE	A	A1	B	C	D	E	F	G	H	I	J
40MM	165	165	38.1	125	73.0	115	12.7	2	98.4	15.87	4
50MM	203	203	50.8	150	92.1	129	14.3	2	120.7	19.05	4
65MM	216	216	63.5	180	104.8	152	15.9	2	139.7	19.05	4
80MM	241	241	76.2	190	127.0	180	17.5	2	152.2	19.05	4
100MM	292	292	101.6	230	157.2	205	22.3	2	190.5	19.05	8
125MM	330	330	127.0	255	185.7	218	22.3	2	215.9	22.22	8
150MM	356	356	152.4	280	215.9	260	23.9	2	241.3	22.22	8
200MM	495	495	203.2	345	269.9	310	27.0	2	298.5	22.22	8
250MM	622	622	254.0	405	323.8	330	28.6	2	362.0	25.4	12
300MM	699	699	304.8	485	381.0	360	30.2	2	431.8	25.4	12

Note : All dimensions are in mm unless and otherwise specified.

DIMENSIONS #300

SIZE	A	A1	B	C	D	E	F	G	H	I	J
40MM	241	241	38.1	155	73.0	140	19.1	2	114.3	22.22	4
50MM	267	267	50.8	165	92.1	160	20.7	2	127.0	19.05	8
65MM	292	292	63.5	190	104.8	162	23.9	2	149.2	22.22	8
80MM	318	318	76.2	210	127.0	220	27.0	2	168.3	22.22	8
100MM	356	356	101.6	255	157.2	232	30.2	2	200.0	22.22	8
125MM	400	400	127.0	280	185.7	265	33.4	2	235.0	22.22	8
150MM	445	445	152.4	320	215.9	298	35.0	2	269.9	22.22	12
200MM	533	533	203.2	380	269.9	330	39.7	2	330.2	25.40	12
250MM	622	622	254.0	445	323.8	355	46.1	2	387.4	28.57	16
300MM	711	711	304.8	520	381.0	380	49.3	2	450.8	31.75	16

PREFERRED INSTALLATION POSITIONS:

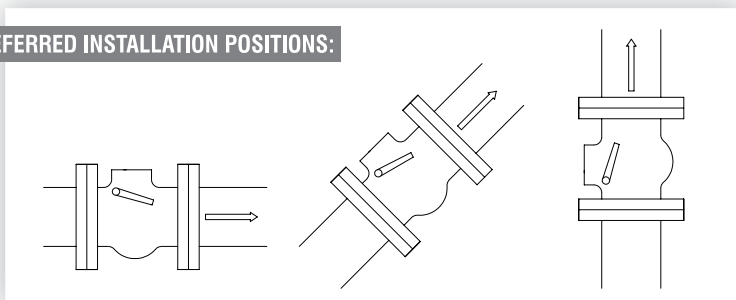

TEST PRESSURE

RATING	BODY (Kg/cm ²)	HIGH PRESSURE SEAT (Kg/cm ²)	LOW PRESSURE SEAT (Kg/cm ²)
#150	30	22	4-7
#300	78	57	4-7

GUARANTEE

All valves are guaranteed against any manufacturing defects for a period of 12 months from date of supply, provided the valves have not been misused, damaged or installed for services they are not recommended. The company shall be liable to furnish part / parts thereof or full valve as the company may deem fit.

V.A. VALVES

ISO 9001-2008 Certified

Regd. Office & Works: Udyog Nagar, Gadaipur, Jalandhar City -144 004

Phone: +91-181-2601540, 2601541 Fax: +91-181-2601741

E-mail : vavalves@vtm-utam.com

Website : www.vtm-utam.com/www.vtm-valves.com

Due to continuous development program, design and data in this leaflet are subject to change without prior notice.

Authorized Stockist

Our associates:



PIONEERING FLUID CONTROLS